

ENDURANCE EPC

VOLTAGE STABILIZER AND PROTECTION OF ELECTRICAL SYSTEMS

ROBUST AND RELIABLE, THE ENDURANCE EPC FROM OCELLOTT IS RESPONSIBLE FOR CONVERTING VARIABLE VOLTAGES FROM 10 VDC TO 36 VDC, STABILIZING THEM AND PROTECTING THE ELECTRICAL SYSTEMS CONNECTED TO IT.





ENDURANCE EPC



VOLTAGE STABILIZER AND PROTECTION OF ELECTRICAL SYSTEMS

The **Endurance EPC** ensures the supply of clean, stable, and safe power for critical electronic equipment.

Modern vehicles with electronic equipment need a voltage stabilizer to ensure uninterrupted operation and protect critical equipment. In addition to protecting critical equipment, the **Endurance EPC** also protects the battery from total discharge.

A strategic defense product already field-validated in the M109 A5+BR armored vehicle

The **Endurance EPC** is also available in the following forms:

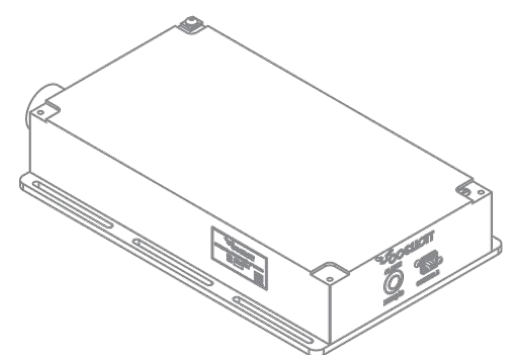
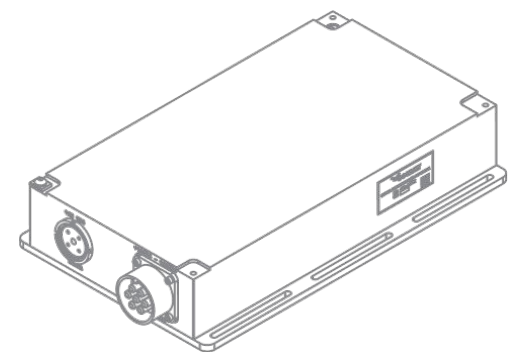

ENDURANCE EPC

Model	Maximum output power	Maximum output current	Accessories
EPC-28V1K	1 kW	36 A	N/A
EPC-28V1KC	1 kW	36 A	4 m input and output cables
EPC-28V500	500 W	18 A	N/A
EPC-28V500C	500 W	18 A	4 m input and output cables



SPECIFICATIONS

ENDURANCE EPC

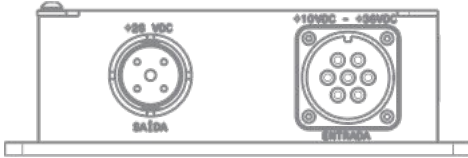

GENERAL SPECIFICATIONS

Input voltage	From +10 VDC to +36 VDC
Stabilized output voltage	+28 VDC ± 0.5 VDC
Efficiency	Greater than 90%
Ripple	Less than 1%
Data interface	Ethernet / IP - SNMPv2 Protocol
Protections	Under input voltage - below +10 VDC Over input voltage - above +36 VDC Thermal protection Output short circuit Reverse polarity protection on input voltage
Operating modes	Low output power when the vehicle is off High output power when the vehicle is on

ENVIRONMENT

Temperature	-40 °C to +85 °C (MIL-STD-810)
Cooling	Conduction to external heat sink
Shock / Drop / Vibration	MIL-STD-810
Immersion	1 meter (MIL-STD-810)
EMI / EMC	MIL-STD-461

STRUCTURE

Dimensions	350mm × 216mm × 70mm
Weight	4.5 kg
Color	Green FED-STD-595B 34094



+55 (12) 3042-0311

MARKETING@OCELLOTT.COM

AV. DR. ALTINO BONDENSAN, 500 CE IV, ROOM 1303, SÃO JOSÉ DOS CAMPOS, SÃO PAULO, BRAZIL

CEP 12247-016

OCELLOTT.COM

